

L638X HIGH VOLTAGE DRIVERS FAMILY
APPLICATION GUIDE

by I. Dal Santo, U. Moriconi

The ST L638X is a versatile high voltage gate driver family.

Realised in BCD Off-line technology, these devices are able to operate with high voltage rails up to 600V. The control inputs are CMOS/TTL compatible and the MOS Gate Drivers provide all the functions and current capability necessary for high side and low side Power MOS and IGBT.

Devices description

The L6380 and L6381 (internal block diagrams in figg.1a and 1b) are single High Voltage/High Side drivers. Especially dedicated to motion control, these devices can be used in all applications (e.g. high voltage buck topologies, active clamp, etc.) where high voltage shifted control is necessary.

For more information on L6380/81 applications, refer to the application note AN881 (low cost active clamp for high frequency using L6380/81).

Figure 1. Internal Block Diagrams.

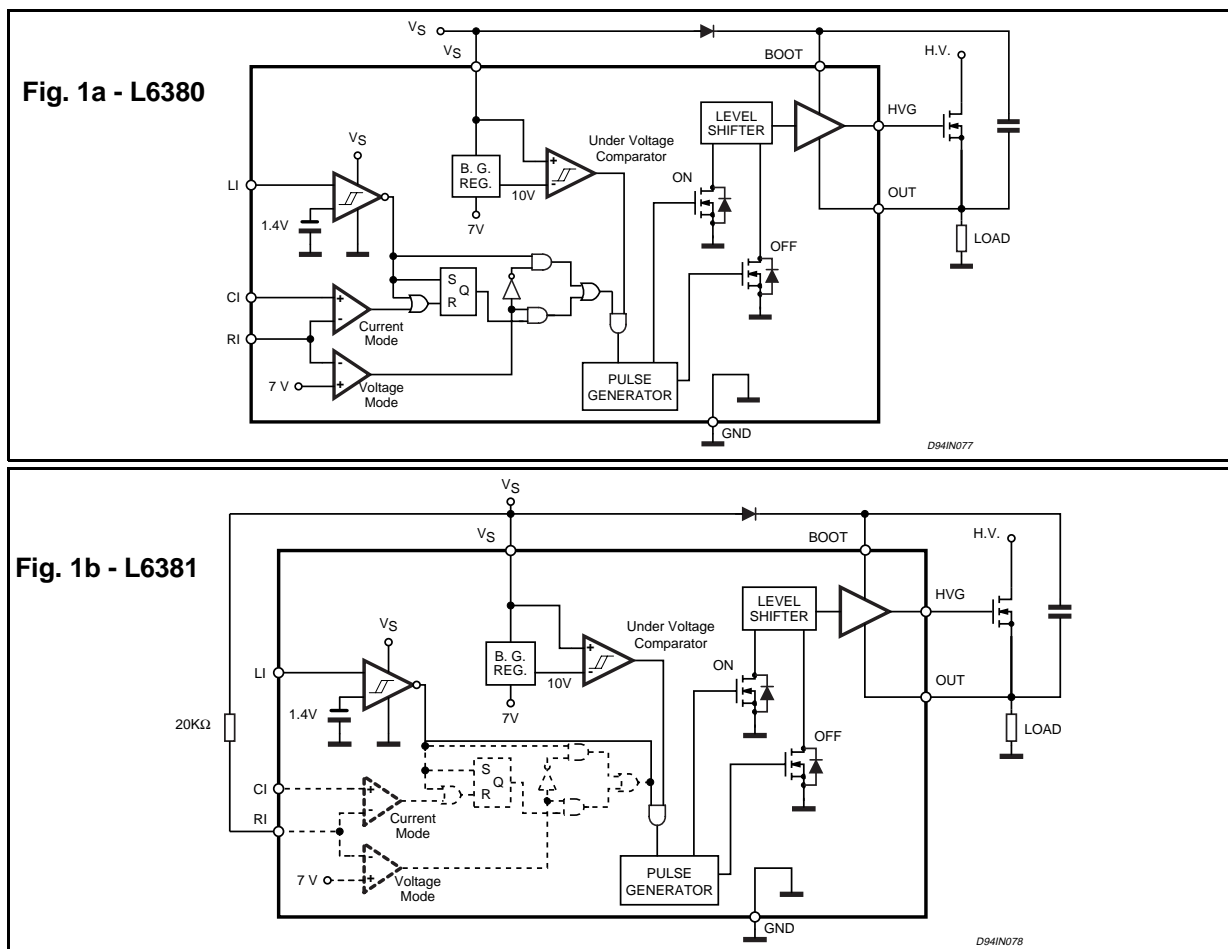

AN994 APPLICATION NOTE

The L6384-5-6 H.V. High and Low side series has been introduced to complete the off-line drivers family.

These new devices, with improved driver current capability are also provided with an internal patented circuitry which replaces the external bootstrap diode. This feature is achieved by means of a high voltage DMOS, synchronously driven with the low side gate driver.

The **L6384** (Internal diagram in fig.2) is a half bridge driver with externally adjustable dead-time and shut down function. To disable the driver, the control pin (DT/SD at pin3) must be pulled down below 0.5V. The dead time can be set from 0.5 μ s to 2.7 μ s by a simple resistor between pin3 and ground.

Available in DIP8 and SO8 packages, this driver can be used in motor controls, resonant converters and lighting applications. In fig.3 the schematic diagram of the evaluation circuit and the layout of the relevant PCB are shown.

Figure 2. L6384 Internal Block Diagram.

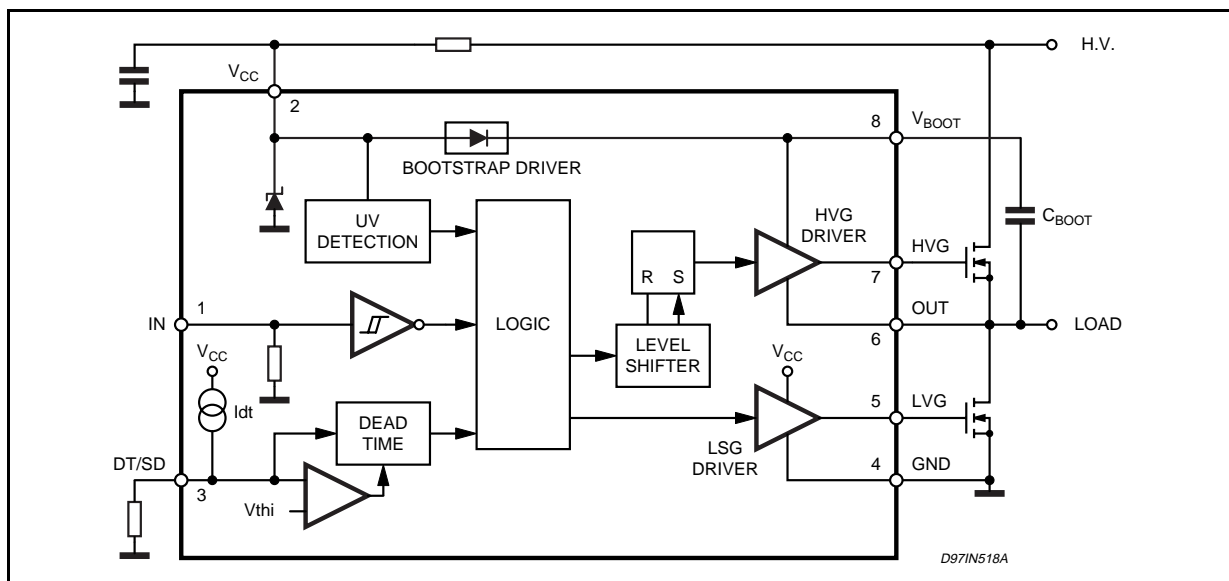

Figure 3. L6384 Schematic diagram of the evaluation circuit.

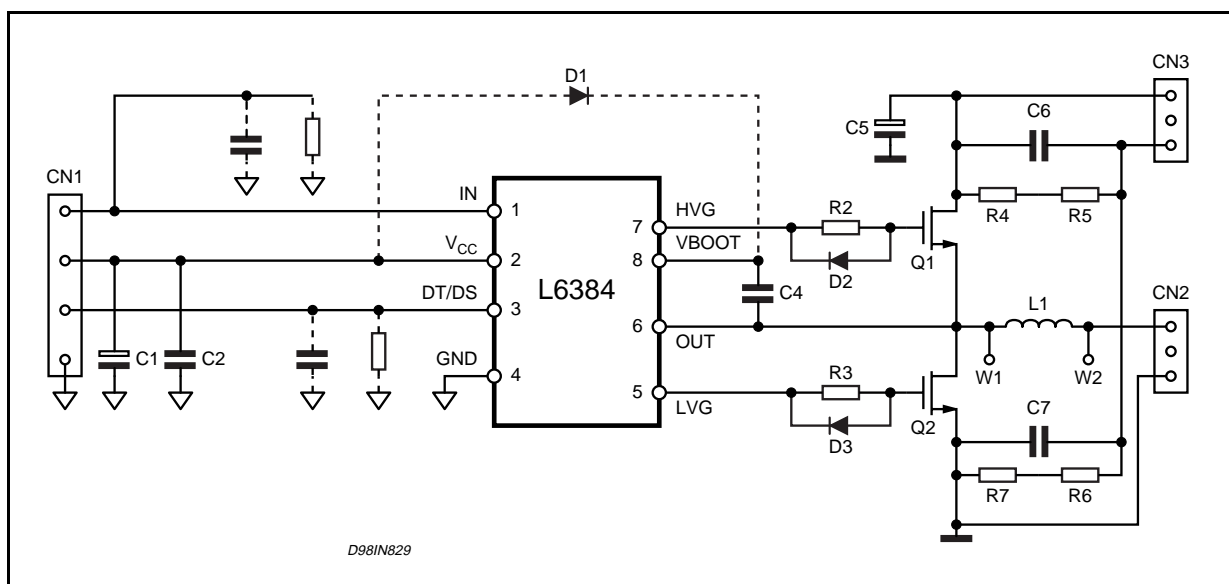
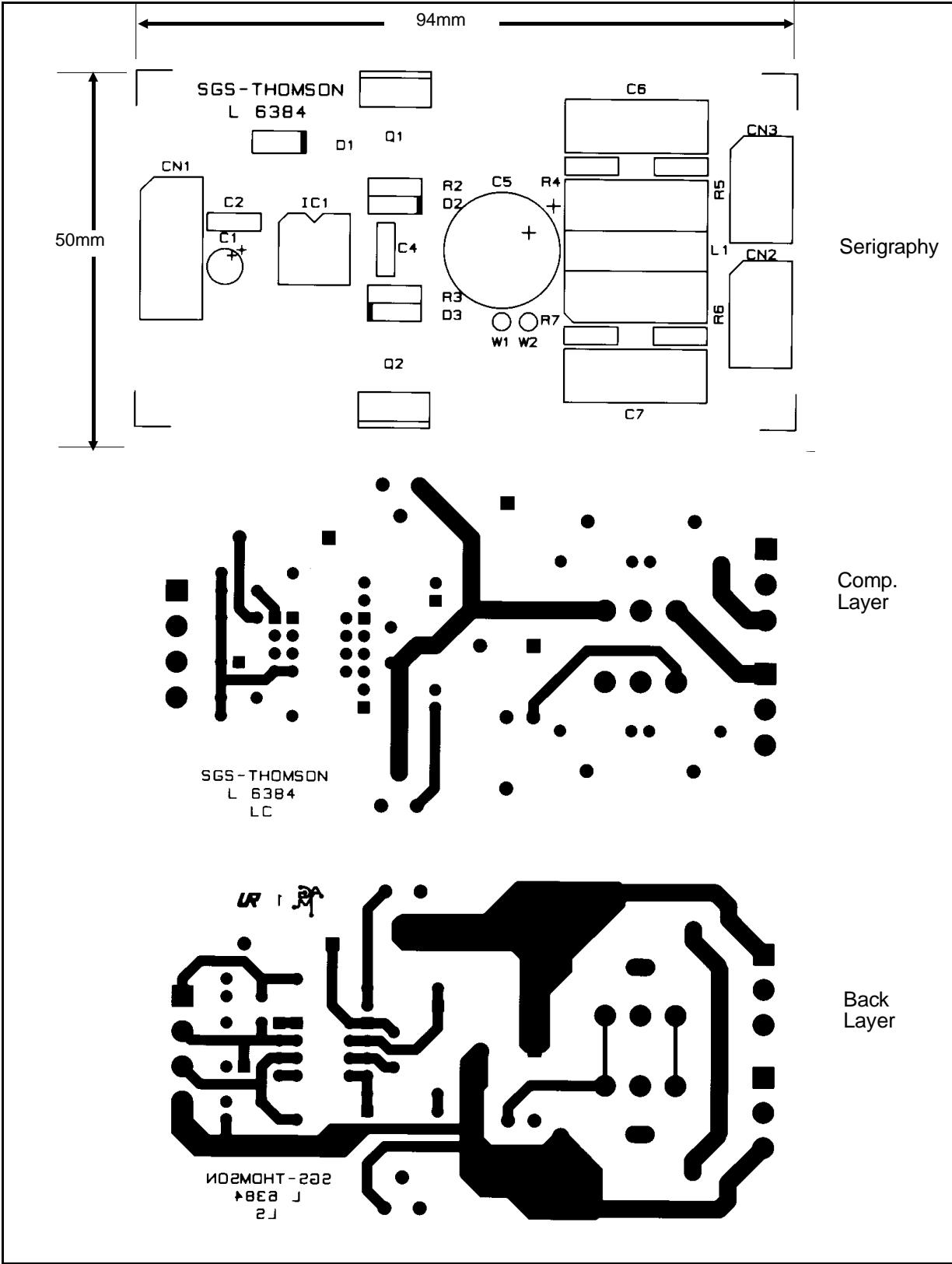

Figure 3a. L6384 - PCB and component layout of the fig. 3.



AN994 APPLICATION NOTE

The **L6385** (Internal diagram in fig.4) is a high and low side configurable driver. In fact, it is possible to control two separate inputs, thus the outputs can be switched independently. This device is provided with undervoltage detection in both low voltage side and high voltage bootstrapped supply. Delivered in 8pin packages, this driver has been especially designed for power supplies and motion control application. Fig.5 shows the schematic diagram of the evaluation circuit and the layout of the relevant PCB.

Figure 4. L6385 Internal Block Diagram.

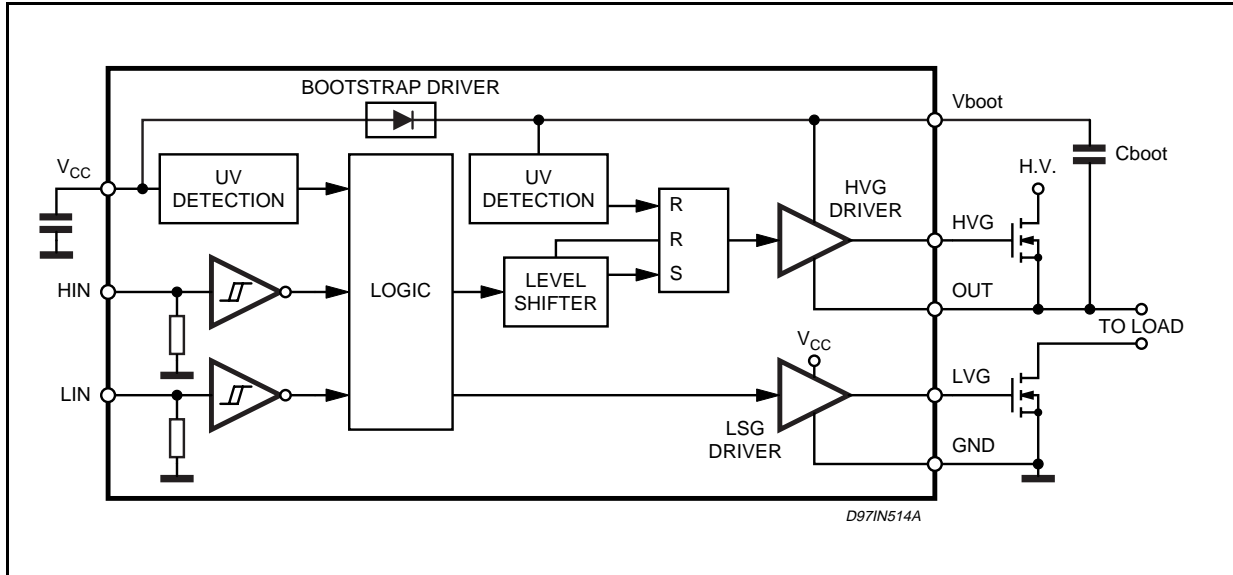

Figure 5. L6385 Schematic diagram of the evaluation circuit.

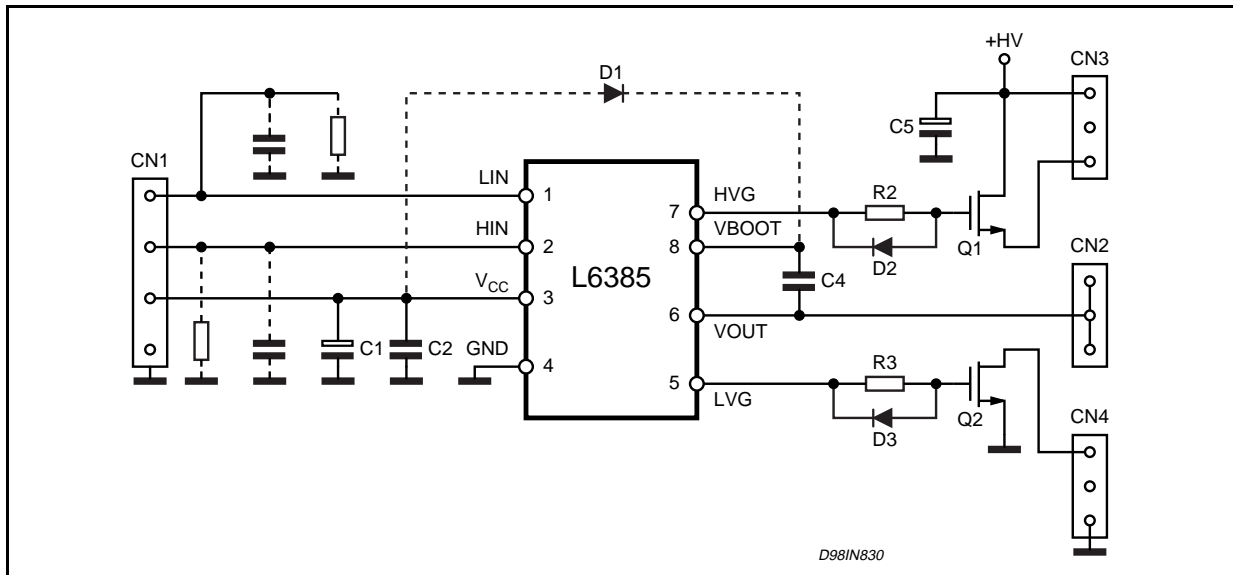
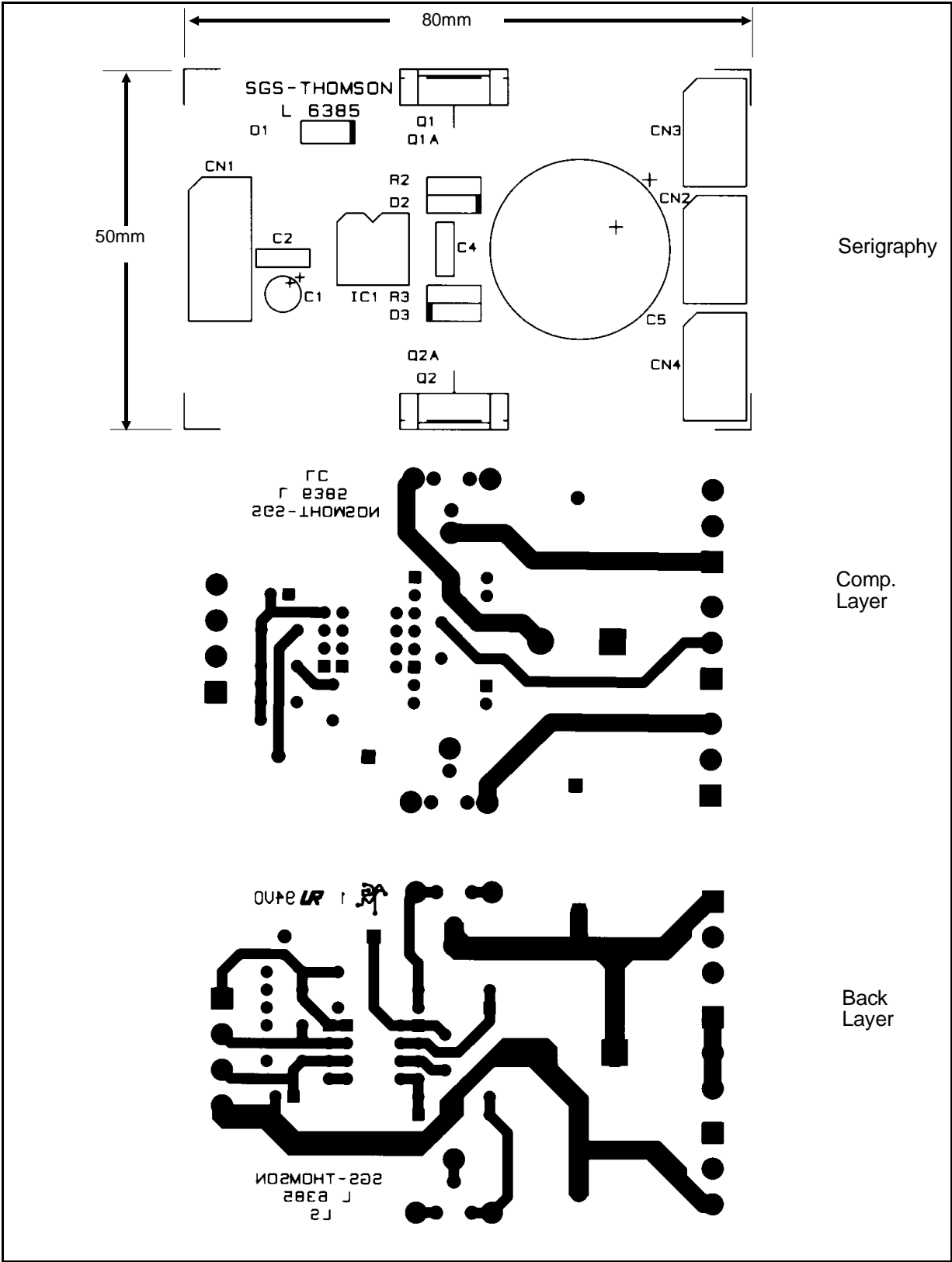

Figure 5a. L6384 - PCB and component layout of the fig. 5.



AN994 APPLICATION NOTE

L6386 (Internal diagram in fig.6). Configurable driver, the L6386 is based on the L6385 structure with added functions. This device is available in DIP14 or SO14.

The added Shutdown function (active low) and the Current Sense Comparator (0.5V threshold) with Diagnostic Output, make this device particularly suitable for motion control with cycle-by-cycle current feedback. Fig.7 shows the schematic diagram of the evaluation circuit and the layout of the relevant PCB.

Figure 6. L6386 Internal Block Diagram.

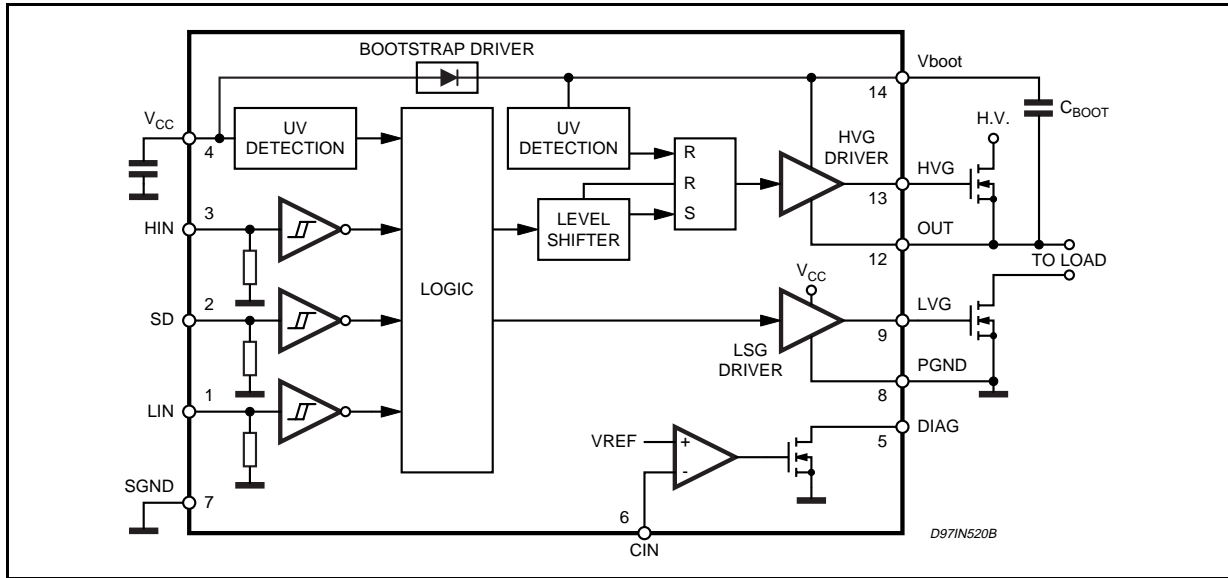

Figure 3. L6386 Schematic diagram of the evaluation circuit.

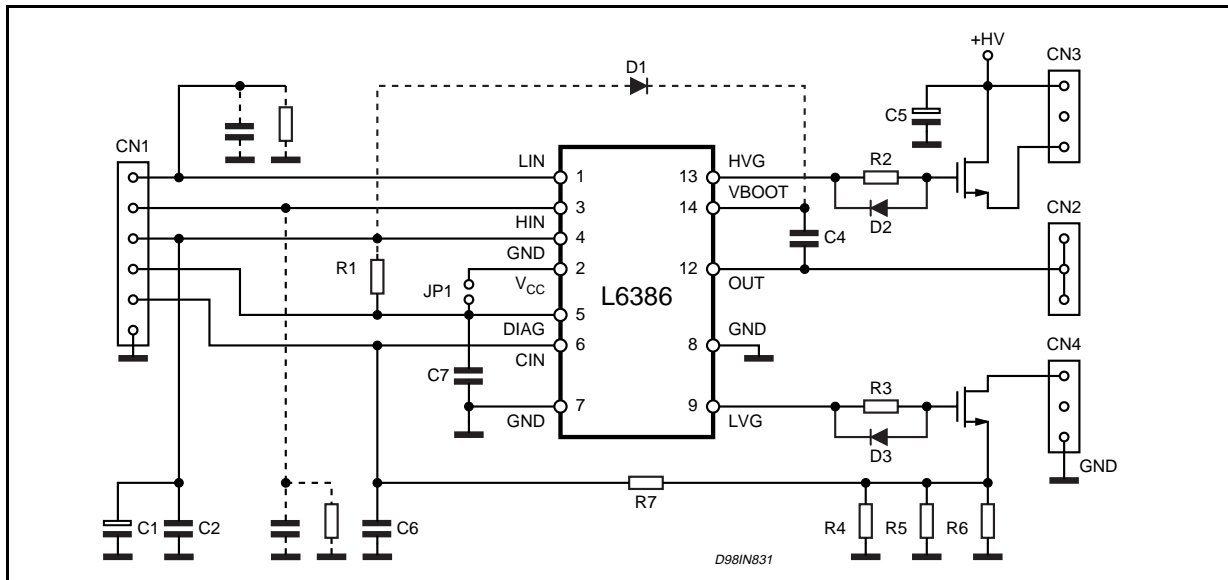
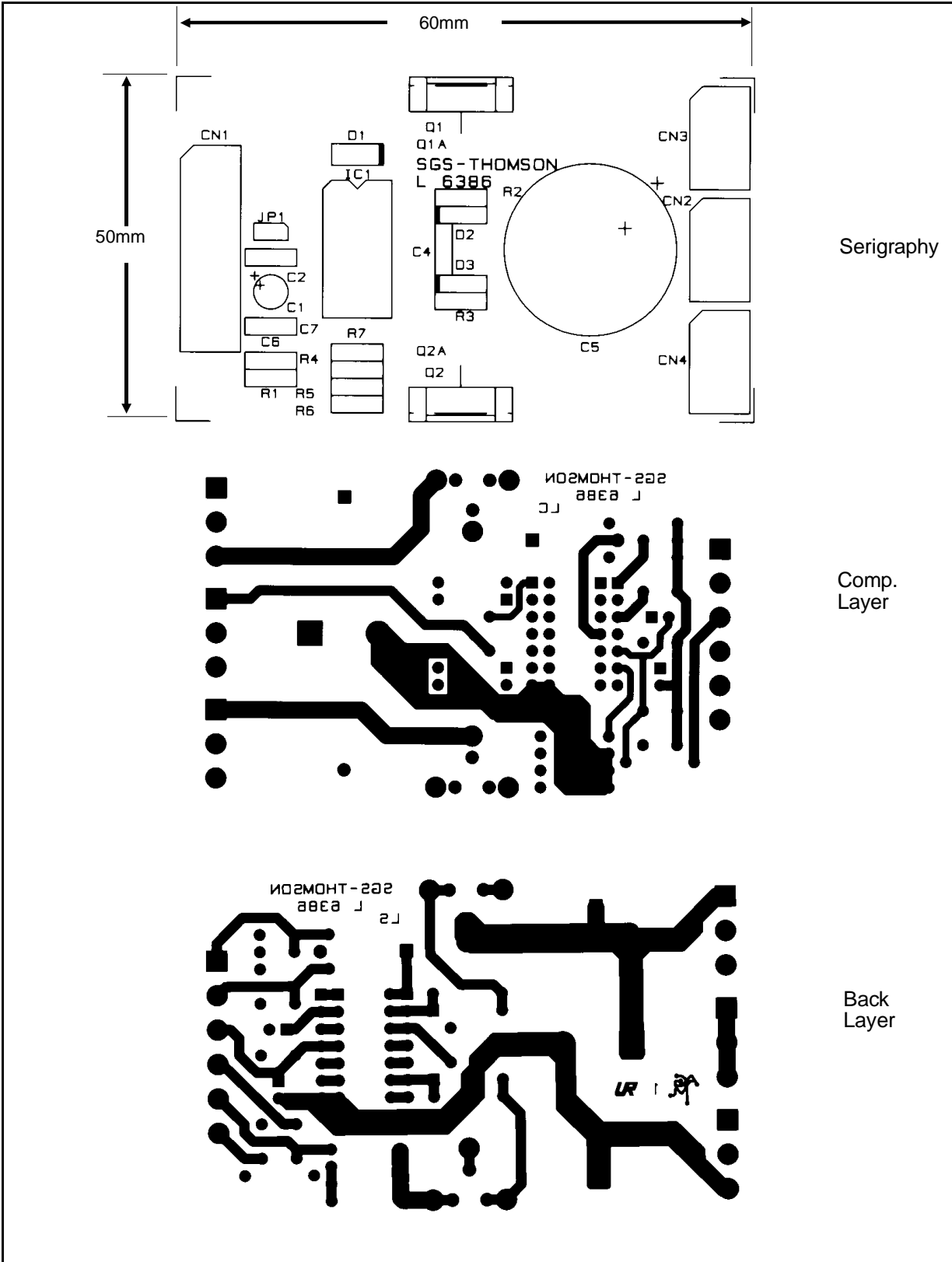

Figure 5a. L6384 - PCB and component layout of the fig. 5.



APPLICATION IDEAS

Here below, follows a collection of application hints that highlight the versatility and flexibility of this family of High and Low side drivers. Moreover their simplicity and compactness make these devices a cost effective solution.

Figure 8. L6384 μ P three-phase motor control.

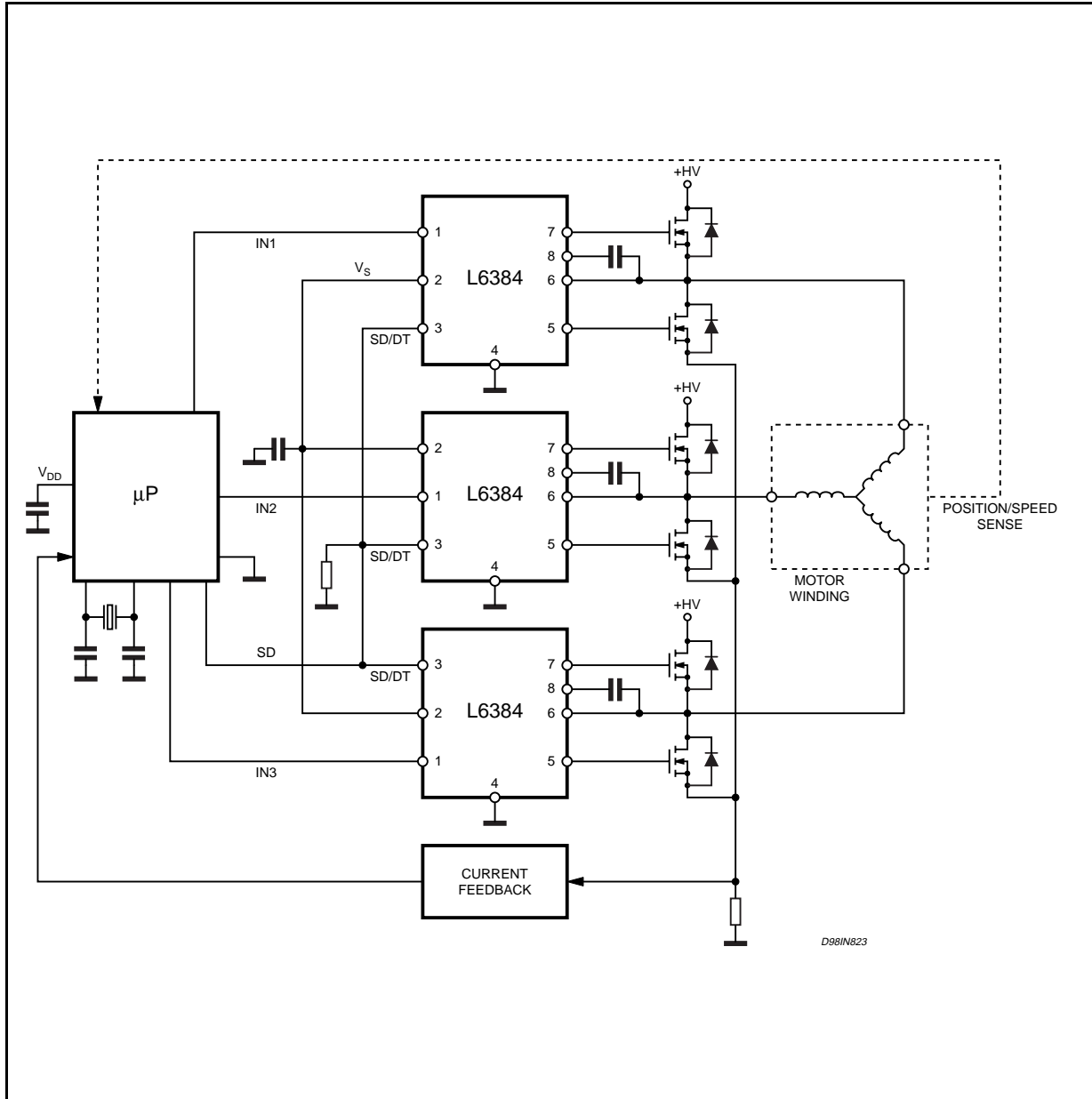

Figure 8. L6384 Dimmable lamp ballast.

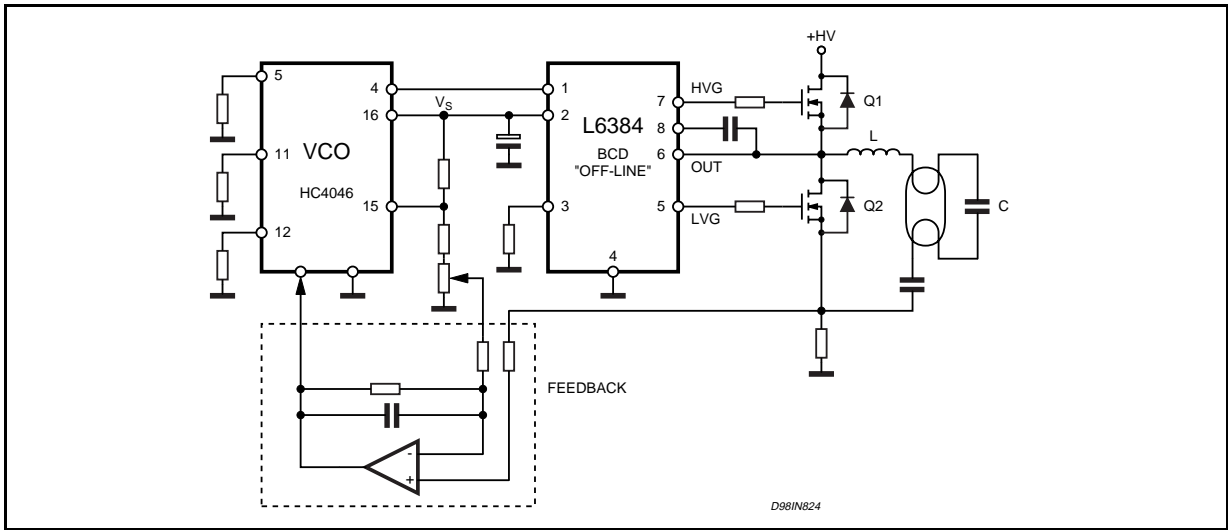

Figure 10. L6385 Horizontal deflection stage.

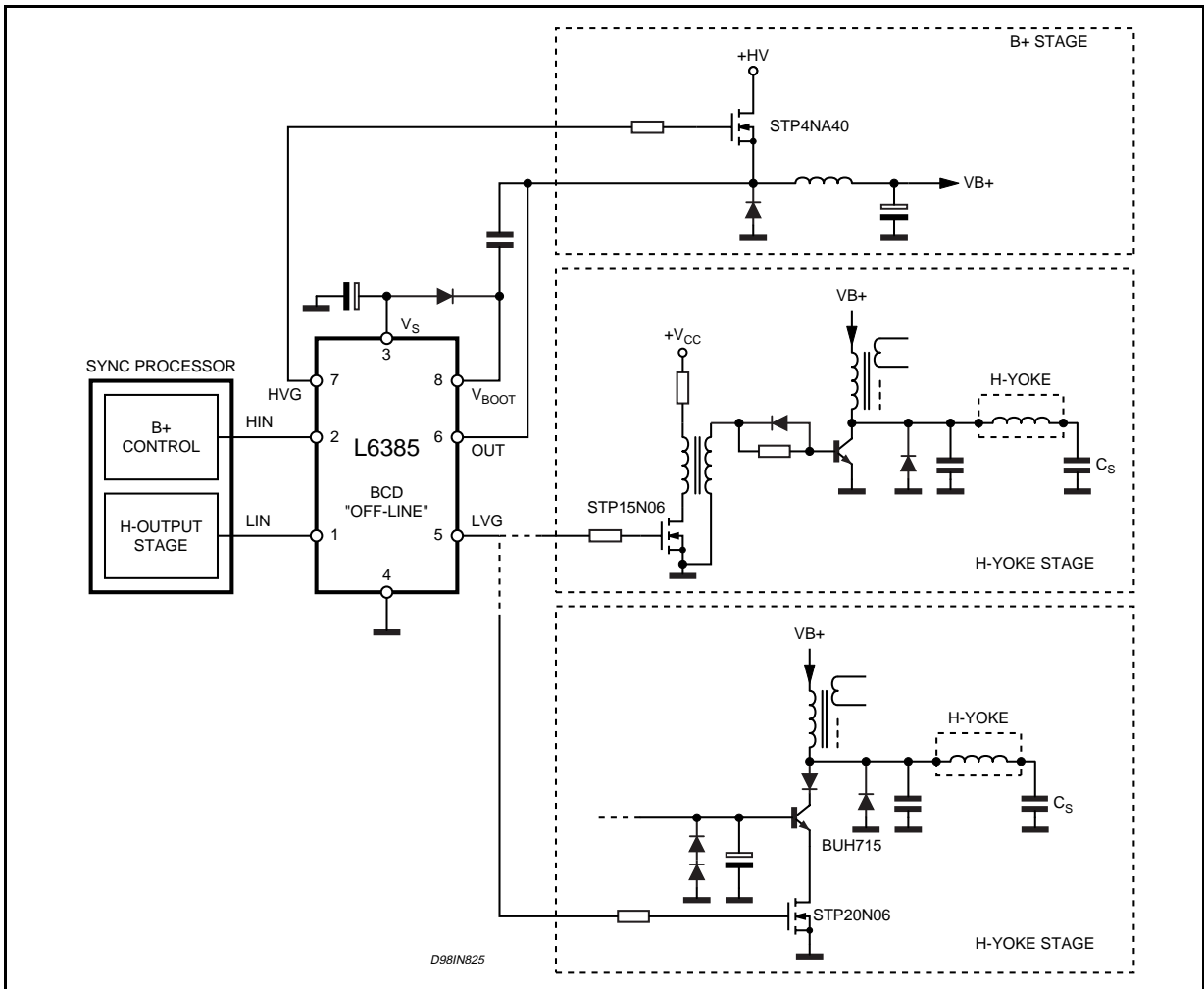

Figure 11. L6385 Two switch forward converter.

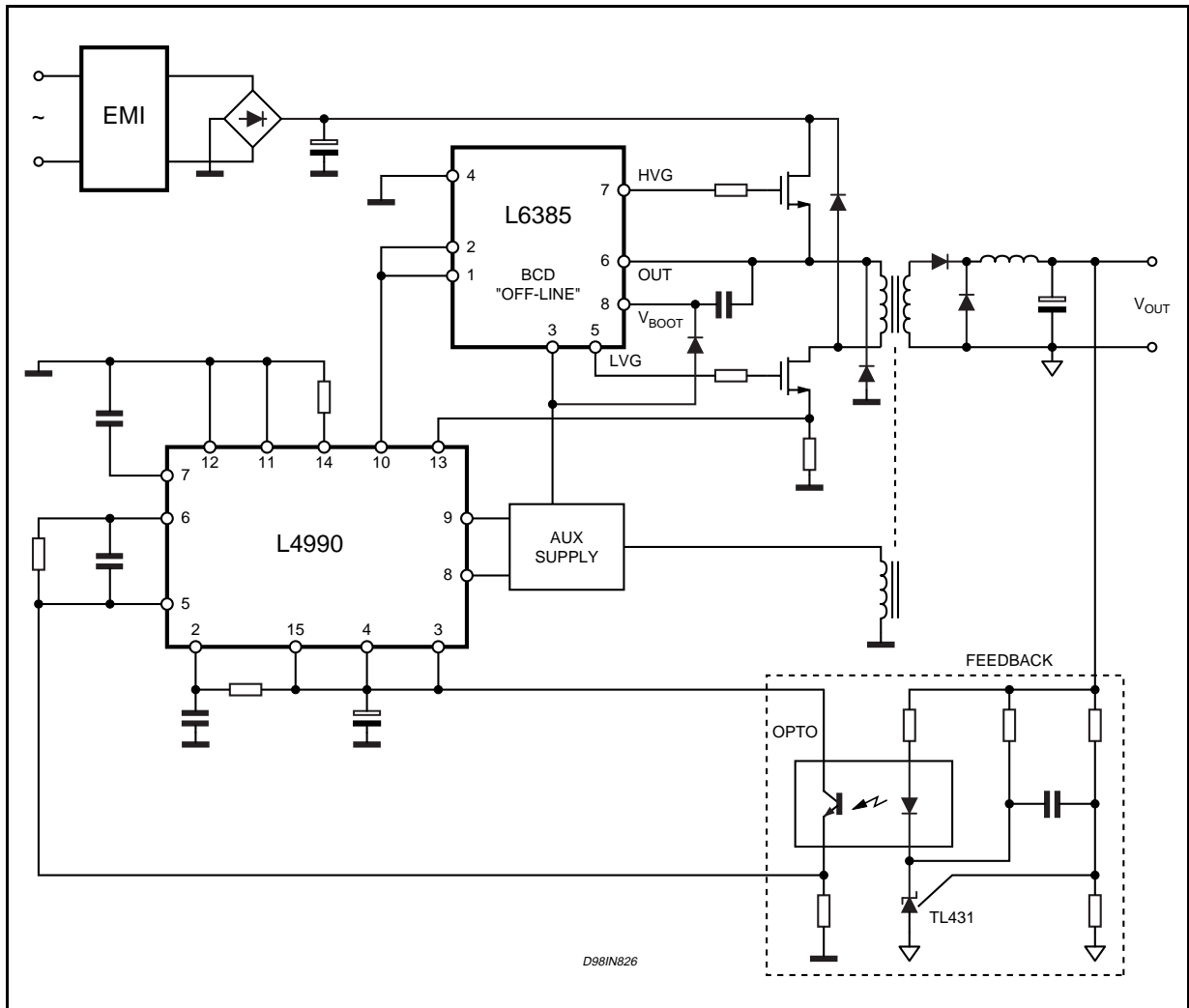

Figure 12. L6385 Asymmetrical half bridge.

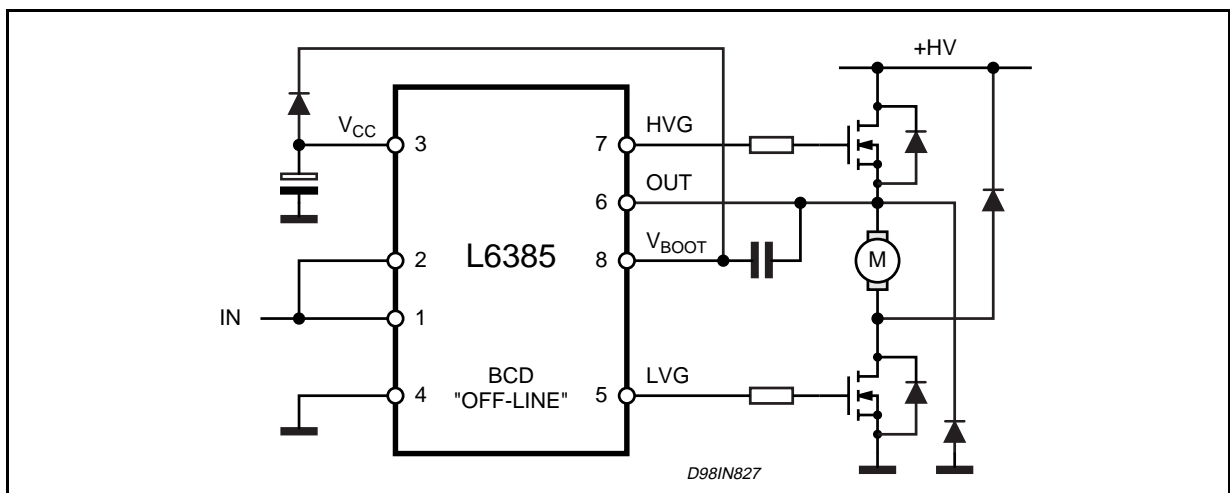
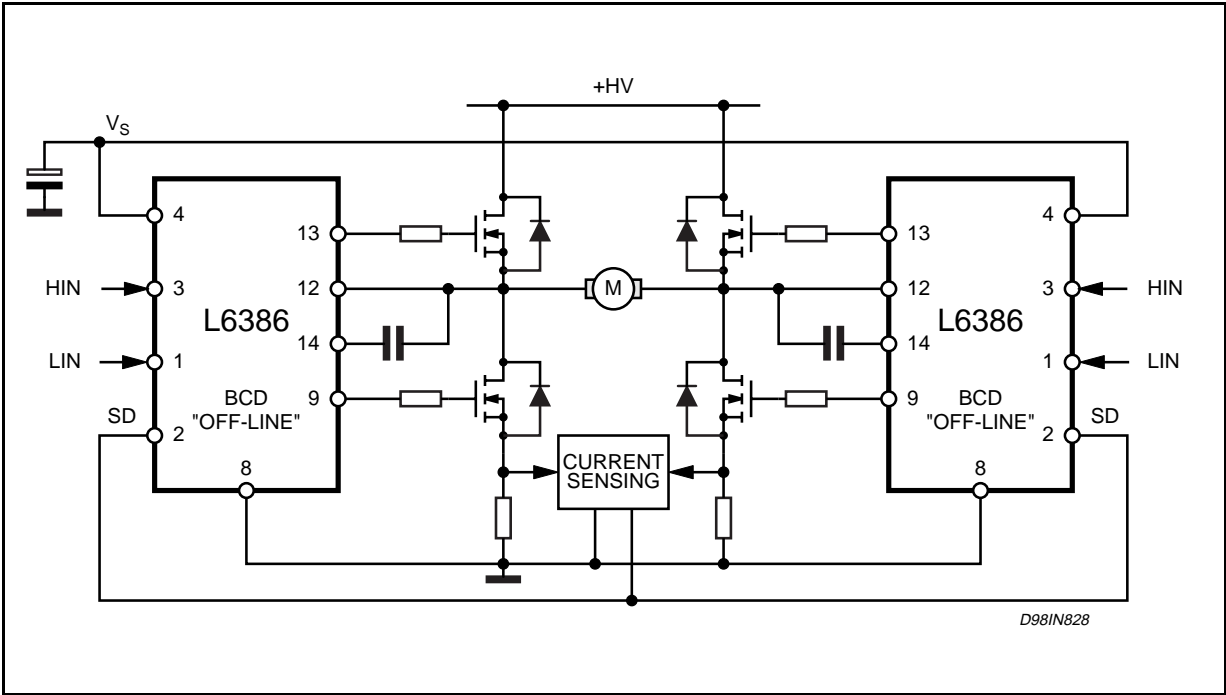

Figure 13. L6386 H-bridge with cycle by cycle control.



Information furnished is believed to be accurate and reliable. However, SGS-THOMSON Microelectronics assumes no responsibility for the consequences of use of such information nor for any infringement of patents or other rights of third parties which may result from its use. No license is granted by implication or otherwise under any patent or patent rights of SGS-THOMSON Microelectronics. Specification mentioned in this publication are subject to change without notice. This publication supersedes and replaces all information previously supplied. SGS-THOMSON Microelectronics products are not authorized for use as critical components in life support devices or systems without express written approval of SGS-THOMSON Microelectronics.

© 1998 SGS-THOMSON Microelectronics – Printed in Italy – All Rights Reserved

SGS-THOMSON Microelectronics GROUP OF COMPANIES

Australia - Brazil - Canada - China - France - Germany - Italy - Japan - Korea - Malaysia - Malta - Morocco - The Netherlands - Singapore - Spain - Sweden - Switzerland - Taiwan - Thailand - United Kingdom - U.S.A.